

# SPINE - CREASER

**For Muller Martini  
1528 & 1529  
cover feeder**



**INSTALLATION GUIDE**

# INSTALLATION

**Important: Please ensure that you read all the instructions before fitting**

**The Spine-creaser double wheel system has been designed to achieve two objectives**

1) Double crease efficiency

- The first wheel helps to produce a cylinder-like crease.
- The second wheel applies an identical crease directly over the first to endorse the quality finish, guaranteeing zero "fibre cracking" along the book spine.

2) Enhanced register

- The two wheels both provide equal contact pressure against the specially formulated creasing matrix, culminating in a much straighter crease line as the book cover is guided around the drum.

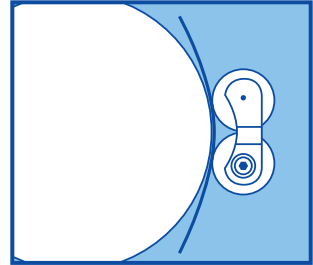

## Three Width Settings

The wheels have three crease width channels to allow narrow, medium or wide options to cater for a vast array of material weights.

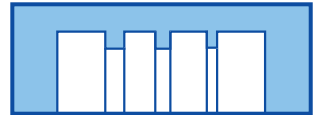

## Creasing Matrix

The specially adapted creasing matrix has been designed to stretch and snap into the feeder drums existing scoring groove.



Both ends of the creasing matrix have an extended tab width to allow a greater contact area for self adhesive application.



# ON GUIDE

*Ensure that the electrical power to the machine is switched off*  
*Remove the panels surrounding the existing male scorer*  
*Use an 8mm Allen key to remove the scoring part*

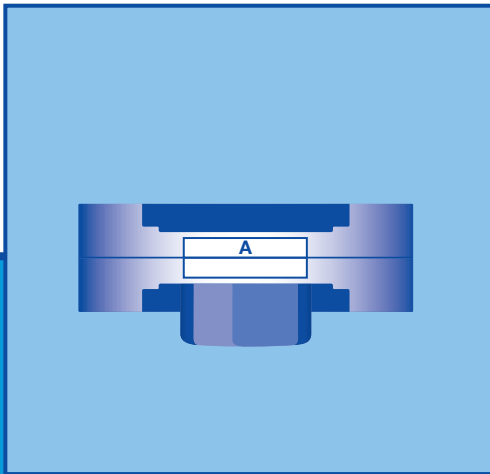

## **Step 1 - Cleaning Drum & Apply Self adhesive Strips**

Engage the cover feeder into forward manual mode. Lift up the cover feeder table to expose the drum. Wipe away excess dirt and dust from the drum circumference with white spirit or similar cleaning agent (concentrate on the scoring groove as this may be the hardest to clean). Dry thoroughly with a cloth. Turn the drum manually until the narrow area is visible. Apply two self adhesive strips, one either side of the scoring groove. Do not peel away self-adhesive backing. See diagram above.

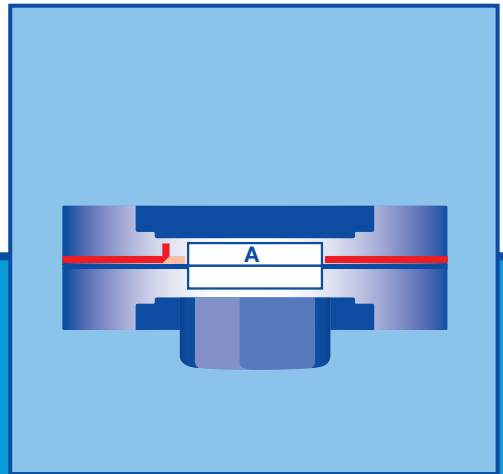

## **Step 2 - Apply Self Adhesive Tape.**

Using the supplied role of self-adhesive tape, apply a full length around the circumference of the drum as close to the scoring groove as possible.

The tape must fall slightly short of the previously affixed self-adhesive strips. This application can be repeated on the other side of the scoring groove to add extra contact strength.

### **IMPORTANT**

Do not peel away the full strip of red plastic backing. Fold over the red plastic backing on left side as illustrated. See diagram above.

# INSTALLATION

DIAG. 1

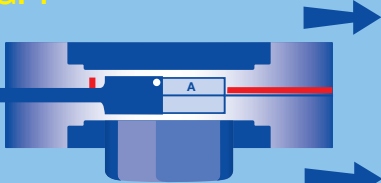

DIAG. 2

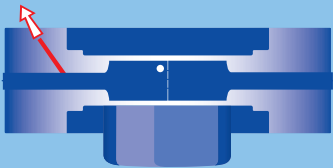

## Step 3 - Applying Creasing Matrix

Peel away self adhesive backing from middle strips (A). Align one end of the creasing matrix and press firmly into position. Begin to stretch the creasing matrix, pushing the V-shaped underside into the scoring groove whilst a second person manually turns the drum in a forward motion. See diagram 1.

When the drum cycle is complete push the second tab firmly on to the adhesive strip so that it meets the first. Gently pull away the full length of red plastic backing without disturbing the creasing matrix above it. See diagram 2.

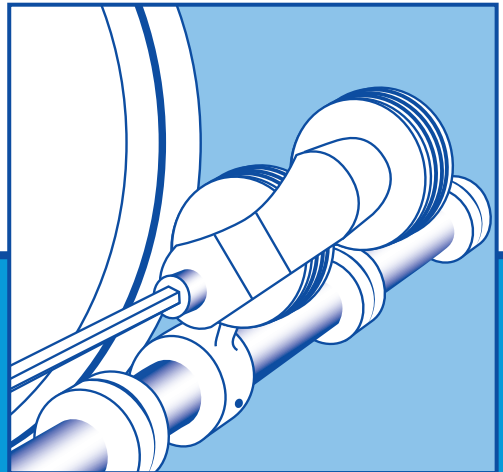

## Step 4 - Install Double Wheel Arm

Attach the Tech-ni-fold double wheel arm into the vacant position left by extracting the existing Male scoring part. In most cases the bolt head should be facing you, although this may be reversed on some types of Muller cover feeder systems. Tighten the bolt with an 8mm Allen key, making sure that the top wheel is sufficiently distanced away from the drum.

# GUIDE CONT...

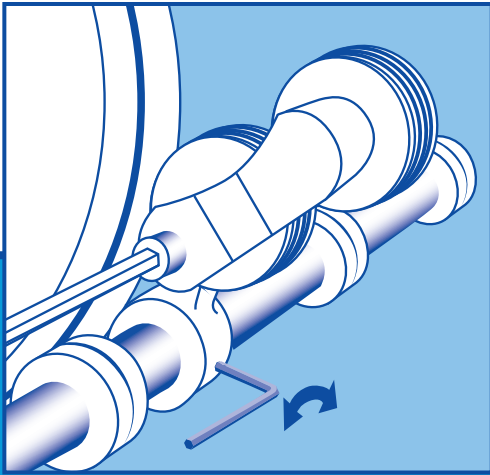

## Step 5 - Loosen Muller Arm

Using a 4mm Allen key loosen the existing Muller arm (the thread will be found on the underside of the arm) See diagram above.

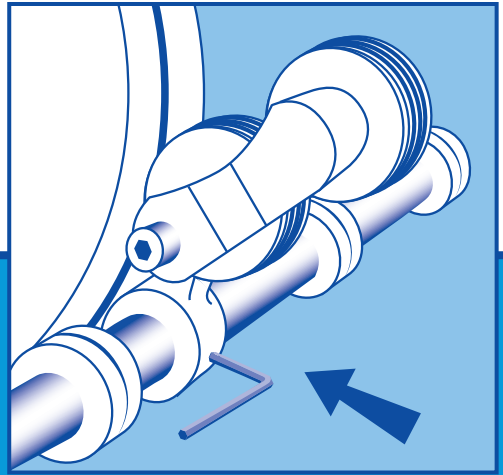

## Step 6 - Aligning Muller Arm with Creasing Matrix

Push the Muller arm towards the creasing matrix, aiming the bottom wheel's central channel lightly against it, tighten the Muller arm thread.

# INSTALLATION GUIDE CONT...

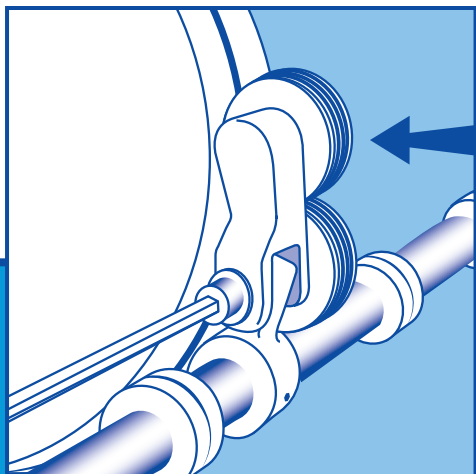

## Step 7 - Placing Top Wheel Against Drum

Loosen the bolt of the Tech-ni-fold arm and push the top wheel lightly against the Creasing matrix & tighten.

### **IMPORTANT**

At this stage please check to make sure that the top wheels middle channel is exactly central to the creasing matrix. It may be necessary to use a torch during this procedure as lighting in this area may be poor.

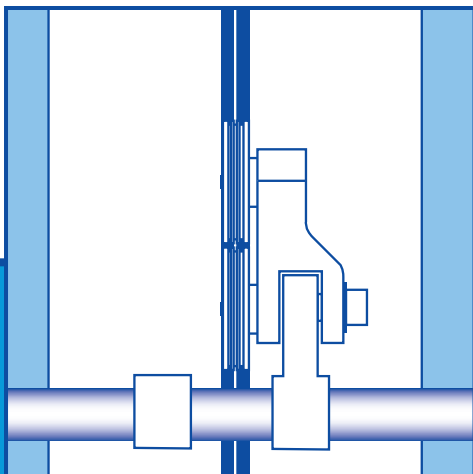

## Step 8 - Installation Check

Now check to make sure that both wheels are applying equal pressure against the creasing matrix. You can gauge this by threading a strip of cover stock material under both wheels, checking for suitable resistance. The matrix should sufficiently grip the cover as it enters both wheels. The wheels should run freely after the cover exits the creasing area.

Use existing fine adjustment dial to plus or minus the strength of crease.

## MATRIX CREASING GUIDE

There are three types of Matrix available to crease the full range of cover stock materials.

● ORANGE = 100 - 135gsm

● WHITE = 135 - 250gsm

● YELLOW = 250 - 350gsm (Wide option)

## RE-USEABLE MATRIX

Each matrix can be carefully peeled off and re-used.

*We also provide creasing solutions for the following machines:*

### Folding Machines

Stahl/Heidelberg  
MBO  
Herzog & Heymann  
Horizon  
Baum  
GUK  
MB  
Shoei  
Longford  
Dick Moll  
Morgana

### Stitchers

Muller Martini  
Heidelberg  
Horizon  
Hohner  
Osako

### Perfect Binding

Muller Martini  
Wohlenberg  
Kolbus  
Horizon  
Harris  
Goss

### Scoring Machines

CreaseStream  
Rollem  
Rosback  
Fidia  
Kluge  
Petratto  
Graphic Wizard



Tech-ni-fold Ltd  
Unit 2  
St John's Business Park  
Lutterworth  
Leicester  
LE17 4HB  
Tel: +44 (0) 1455 554491  
Fax: +44 (0) 1455 554526  
Email: [info@technifold.co.uk](mailto:info@technifold.co.uk)  
Website: [www.technifold.com](http://www.technifold.com)