



Global Leaders In Creasing Technology

Spine Creaser For Horizon Stitchliner

For Models 6000 and below

Installation Guide

WARNING

Ensure that the electrical power to the machine is switched **OFF** before the installation of the Tech-ni-Fold Spine Creaser.

Installation of the Spine Creaser

1

- Remove the top-creasing cassette by unlocking the tension bars (A).
- Remove the 5mm hexagon screws and studs (B). The cassette can now be removed from the machine.

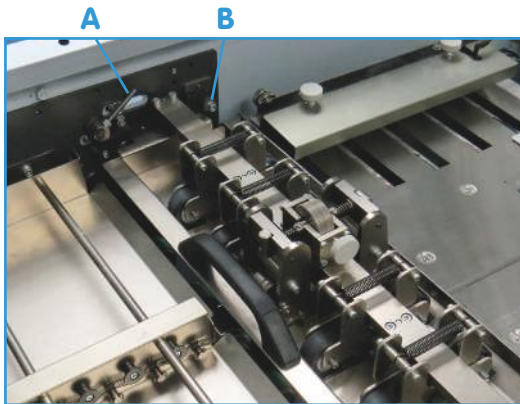

2

- Remove the 2 screws (A).
- Remove the flat bottom plate.

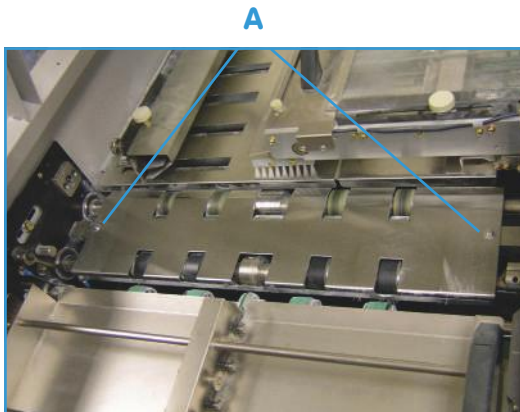

3

- Unscrew the 2 bottom collars and the old rubber creaser (A).
- Each collar has 2 x 2.5mm screws.

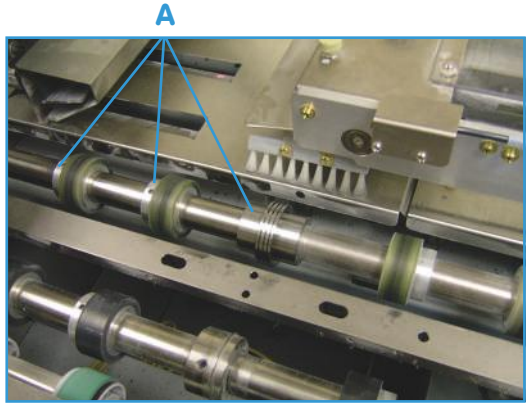

4

- Unscrew the 4 screws and remove the guard.



5

- Release the belt pulley 2 x 3mm hexagon screws (A) and then unscrew the 2 x 2.5mm screws (B) that hold the bearing into the frame on the machine. The bearing can now be removed.

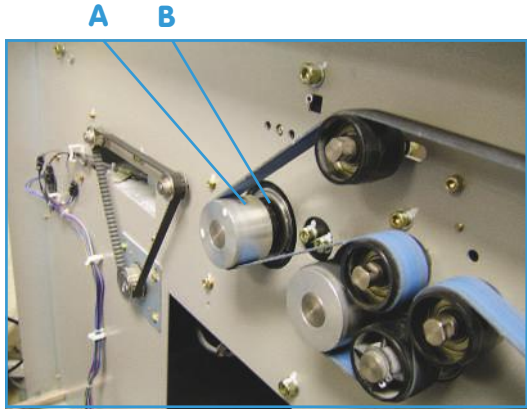

6

- Slide off the 2 support collars, the circlip and the old rubber creasing roller.
- Slide the **new female** into the centre of the shaft and replace the 2 collars.
- Replace the bearing, belt pulley and the machine guard.



7

- Align the new female by removing the special alignment setting tool (this is attached to the main framework situated next to the plough folding unit as shown in diagram.)

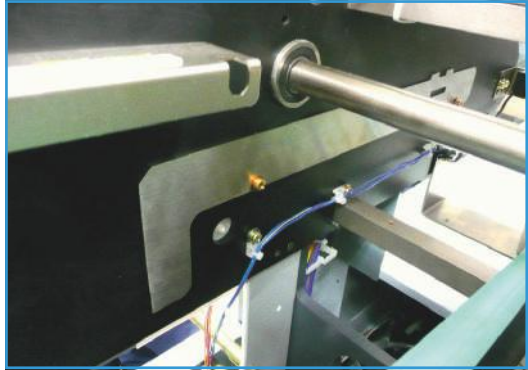

8

- Place the tool (A) along the main framework and align the centre female channel with the setting mark on the tool (B) and tighten screw. Replace the flat plate guard. The bottom shaft is now ready to use.

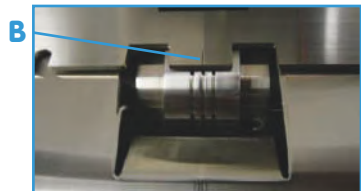
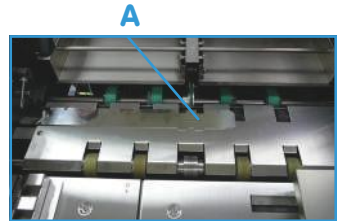

9

- Remove the 4 screws (A) from the removed top creasing unit.

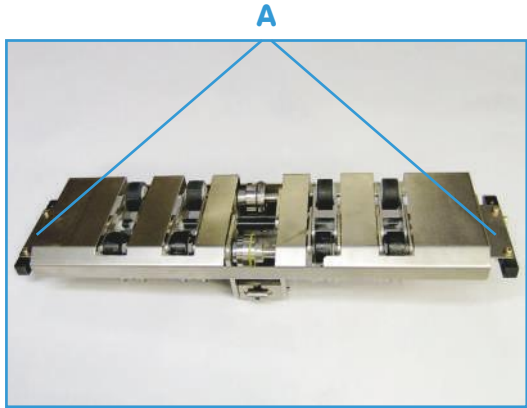

10

- Remove cylinder nut (A).
- Release the 2 small collars (B).

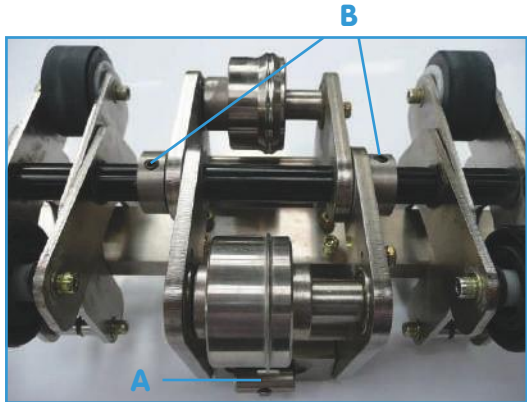

11

- Remove the support shaft screws (C).
- Release the creasing shaft, simply pull the framework apart (D).

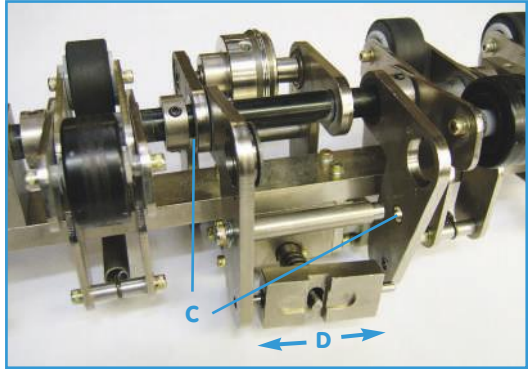

12

- Replace the old spring with the supplied stronger spring (A).

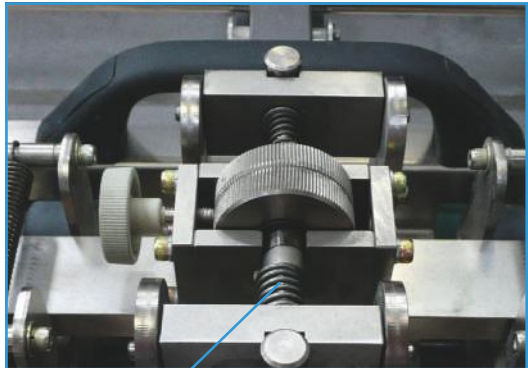

A

13

- Replace the old male creaser with the new male device (A).
- Reassemble in reverse order and return the top unit back onto the main machine.

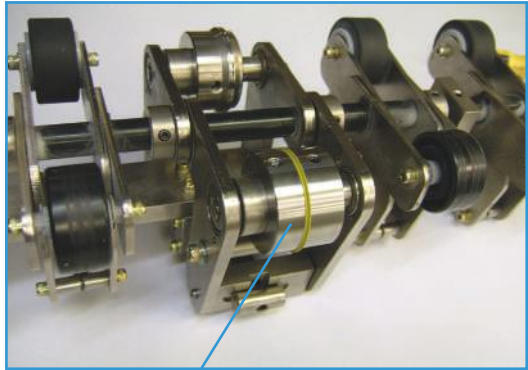

A

14

IMPORTANT – Aligning the Male Part

- Position the male holder so that the rubber insert fits into the central female setting.
- Place a piece of medium stock paper in between the male and female.
- Rotate the shafts by using the black manual knob or gently pull out the sheet as it is held between the male and female components. This will automatically line up the creasing unit.
- As the fixing screw comes into view lock in position.

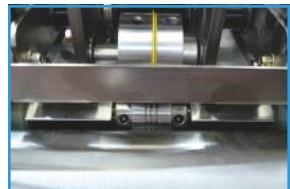

15

- Please use screw (A) to adjust pressure settings.

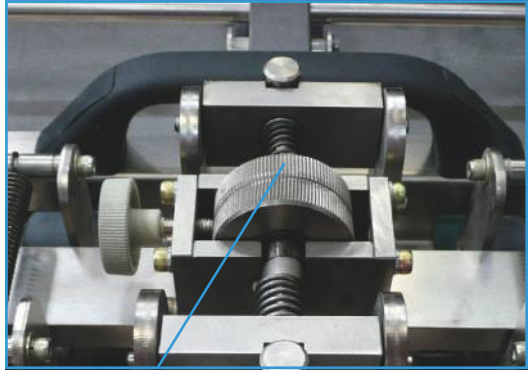

A

16

- REMEMBER - Maximum results can only be achieved through central alignment of the male and female on both the plough fold and the new Tech-ni-Fold creasing system.

The machine is now ready to run.



The centred top & bottom creasing units

Insert Creasing Guide

● Blue = 150-250gsm

● Yellow = 250-350gsm

Rubber inserts = Difficult cover stocks that fibre crack easily

Plastic inserts = Normal cover stock where cracking is not a problem

Now Available: Extra Wide and Deep Plastic Creasing Inserts – To be ordered separately

We also provide creasing solutions for the following machines:

Folding Machines

Stahl/Heidelberg

MBO

Herzog & Heymann

GUK

Horizon

Shoei

Baumfolder

Morgana

MB

Rollem (scoring machines)

Rosback (scoring machines)

Multigraf (scoring machines)

CreaseStream (creasing machine)

And more...

Stitchers

Muller Martini

Heidelberg

Hohner

Osako

Duplo

And more...

Perfect Binders

Muller Martini

Kolbus

Wohlenberg

Horizon

And more...



Tech-ni-Fold Ltd

Unit 2

St John's Business Park

Lutterworth

Leicester

LE17 4HB

United Kingdom

Tel: +44 (0) 1455 554491

Email: info@technifold.co.uk

Website: www.technifold.com